

Owners Manual

Product Code: 6056T

**MADE FOR THE
TRADE**

TQ TRADEQUIP
the trusted brand in equipment

**MOBILE WORKSHOP
TABLE – 1 DRAWER**



Specifications:

- 340 x 300 x 45mm Drawer
- Adjustable from 860-1200mm
- Includes drawer and top tray liner
- 80kg Distributed Load Capacity
- 730 x 500 x 25mm
- Gross Weight: 20kg

About the **TradeQuip** brand

The '**TradeQuip**' brand of workshop equipment, is designed for use in a demanding workshop environment by professional users. With proven and trusted "Made for the Trade" reliability, 'TradeQuip' branded products offer the very best in performance for an affordable price. All backed by a 1year trade guarantee across 1,000+ distributors Australia wide.

TQ TRADEQUIP
the trusted brand in equipment

TQPRO
Trusted by serious professionals

BORUM
INDUSTRIAL WORKSHOP EQUIPMENT

WARNING



IMPORTANT: PLEASE READ THESE INSTRUCTIONS CAREFULLY. NOTE THE SAFE OPERATIONAL REQUIREMENTS, WARNINGS & CAUTIONS. USE THE PRODUCT CORRECTLY AND WITH CARE FOR THE PURPOSE FOR WHICH IT IS INTENDED. FAILURE TO DO SO MAY CAUSE DAMAGE AND/OR PERSONAL INJURY, AND WILL INVALIDATE THE WARRANTY. PLEASE KEEP INSTRUCTIONS SAFE FOR FUTURE USE.

CONTENT

WARNING 2

CONTENT 2

SAFETY INSTRUCTIONS 2

FEATURES & SPECIFICATIONS 2

ASSEMBLY INSTRUCTIONS 3

PARTS DIAGRAM & PARTS LIST 4

WARRANTY 5

SAFETY INSTRUCTIONS

- ✓ Only use this Mobile Workshop Table for the purpose for which it has been designed.
- ✗ Do not modify any component of this Mobile Workshop Table.
- ✓ When servicing, use only TradeQuip identical replacement parts. Use of any other parts will void the warranty.
- ✓ Distributed load capacity: 80kg
- ✓ This product is intended for indoor use only.



FEATURES & SPECIFICATIONS

Featuring a convenient drawer, the Heavy Duty steel construction makes this **TradeQuip "Made for the Trade"** Mobile Workshop Table durable enough for moving tools and car parts to and from the vehicle. Easily handles loads up to 80kg. Ball bearing castors ensure you can manoeuvre this mobile workshop table around the workshop. Including 3 compartments and 6 mounting holes, the height adjustment gives you plenty of options for lowered cars or SUV's. This very versatile mobile work top makes any installation or service work flow more efficiently for auto repairers and installation workshops.

<p>Features:</p> <ul style="list-style-type: none"> • Height adjustable for most vehicles • Ball Bearing wheels for easy moveability • Multi-functional top table with 3 compartments & 6 screwdriver holes • Top EVA mat for skid resistance • Extra drawer for more storage room 	<p>Specifications:</p> <ul style="list-style-type: none"> • 340 x 300 x 45mm Drawer • Adjustable from 860-1200mm • Includes drawer and top tray liner • 80kg Distributed Load Capacity • 730 x 500 x 25mm • Gross Weight: 20kg
--	---

ASSEMBLY INSTRUCTIONS

Tools needed to Assemble Unit:

- 17mm Wrench
- 14mm Wrench

1. Using four 14mm bolts, washer and nuts, install one castor in each square hole on the bottom edge support (#7 & #11). Be sure the square bolster on the post of each castor inserts fully into the square hole in the support before fully tightening.
2. Using four 14mm bolts & washers, attach the bolt plate on the right support (#7) to the bracket on the tube support (#10), ensuring that the castors are facing down. Be sure bolts are securely tightened before proceeding.
3. Slide left support tube (#11) into the tube support (#10) and secure with 17mm bolt and curved washer (#12). The curved washer should conform to the tubing wall.
4. Laying the top tray (#1) upside down on the floor, attach the mounting bracket onto silver adjusting tube (#5) to the bracket on the bottom of the tray, being sure the adjusting tube faces **away** from the centre on the top tray.
5. Now, slide the silver adjusting tube with top tray attached into the tube support (#10) and secure at the desired height with the T-Bold (#6).
6. Attach four rubber protector bumpers (#2), by pushing the black plastic pins provided into the holes in the corners of the top tray. The pins are inserted from **outside** the tray toward the inside, being sure the rubber bumpers overlap the top edge of the tray.
7. Install the three small rectangular plastic inserts (#3), into the reinforcement bars under the top tray. Install the four large rectangular plastic inserts (#*) into the four holes on the left and right supports (#7 & #11).



PARTS DIAGRAM & PARTS LIST

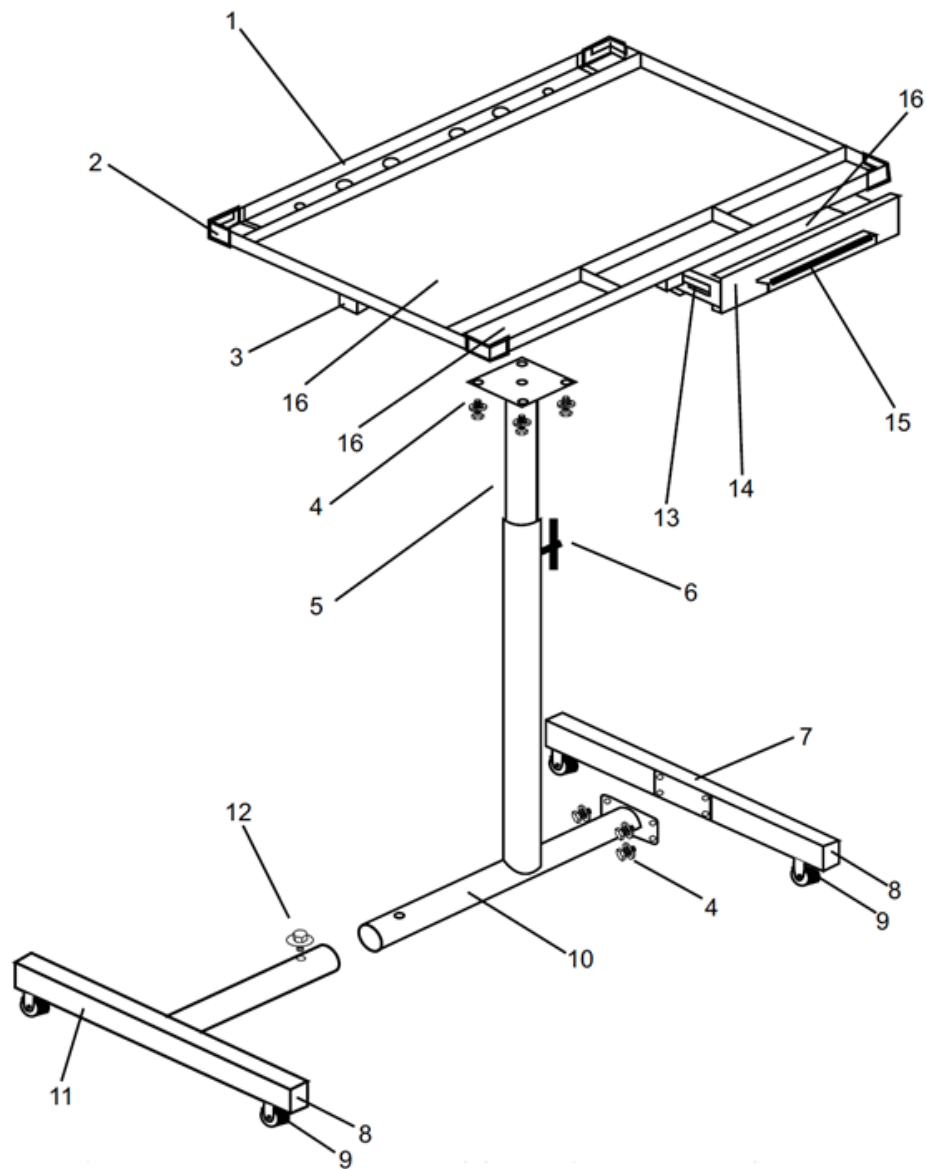

Part	Description	Qty
1	Top Tray with Rubber Liner	
2	Rubber Corner Bumper W/Pins	4PCS
3	Small Plastic Insert	3PCS
4	14mm Bolt with Washer	8PCS
5	Adjustable Tube (Silver)	
6	T-Bolt	
7	Right Support	
8	Large Plastic Insert	4PCS

Part	Description	Qty
9	2" Castor with Nut	4PCS
10	Tube Support	
11	Left Support	
12	17mm Bolt with Curved Washer	
13	Ball Bearing Slide (Pair)	1PAIR
14	Drawer Unit (with EVA Pad)	
15	Aluminium Handle	
16	Pad Set	5PCS

WARRANTY

TradeQuip products have been carefully tested and inspected before shipment and are guaranteed to be free from defective materials and workmanship for a period of 12 months from the date of purchase except where tools are hired out when the guarantee period is ninety days from the date of purchase.

Should the machine develop any fault, please return the complete tool to your nearest authorised warranty repair agent or contact TQB Brands Pty Ltd Warranty team – warranty@tqbbrands.com.au.

If upon inspection it is found that the fault occurring is due to defective materials or workmanship, repairs will be carried out free of charge. This guarantee does not apply to normal wear and tear, nor does it cover any damage caused by misuse, careless or unsafe handling, alterations, accident, or repairs attempted or made by any personnel other than the authorised TQB Brands Pty Ltd repair agent.

This guarantee applies in lieu of any other guarantee expressed or implied and variations of its terms are not authorised.

Your TQB Brands Pty Ltd guarantee is not effective unless you can produce upon request a dated receipt or invoice to verify your proof of purchase within the 12 month period.

Consumer Guarantee

Our goods come with a guarantee that cannot be excluded under the Australian Consumer Law. You are entitled to a replacement or refund for a major failure and compensation for any other reasonably foreseeable loss or damage. You are also entitled to have the goods repaired or replaced if the goods fail to be of acceptable quality and the failure does not amount to a major failure.



All images and illustrations shown are for reference purposes only. All information, specifications and illustrations in this manual are based on the latest information available at the time of publication and are subject to change without notice. The information in this manual is periodically revised to ensure the latest information is included. Download the latest version of this manual and other related technical documentation from www.tqbbrands.com.au.